

LUMINA



REFRIGERAZIONE



LUMINA

Design Arch. Baldochi



Bastano solo pochi segni per dare sostanza alla materia.
È bastata solo un'idea per illuminare il mondo.

Just a few signs to give substance to the matter.
Just an idea to light up the world.





LUMINA non vuole essere una rivoluzione ma un passo avanti, per dare una nuova magica prospettiva alle vetrine per pasticceria e gelateria.

LUMINA does not want to be a revolution but a step forward to give a new magic perspective to pastry and gelato showcases.



Forma e sostanza si fondono esaltando l'elevato contenuto tecnologico e di affidabilità, che da sempre ha fatto di FB il sogno dei nostri clienti.

Form and substance are blended together to enhance the highly technological content and reliability that has made FB the dream of our customers.



Il design di LUMINA è riuscito a coniugare le linee spigolose, addolcendole. Il risultato è quello di aver rinnovato il gusto attualmente più diffuso, fatto di linee spigolose ed eleganza minimale, rendendolo ancor più raffinato: il segno inconfondibile di uno stile unico: quello di FB.

LUMINA's design combines pointy profiles, being also able to soften them. The result is a renewed taste which follows the most current fashions made of sharp lines and minimalist elegance. But it goes further making it even more refined and recognizable as FB's unique style.

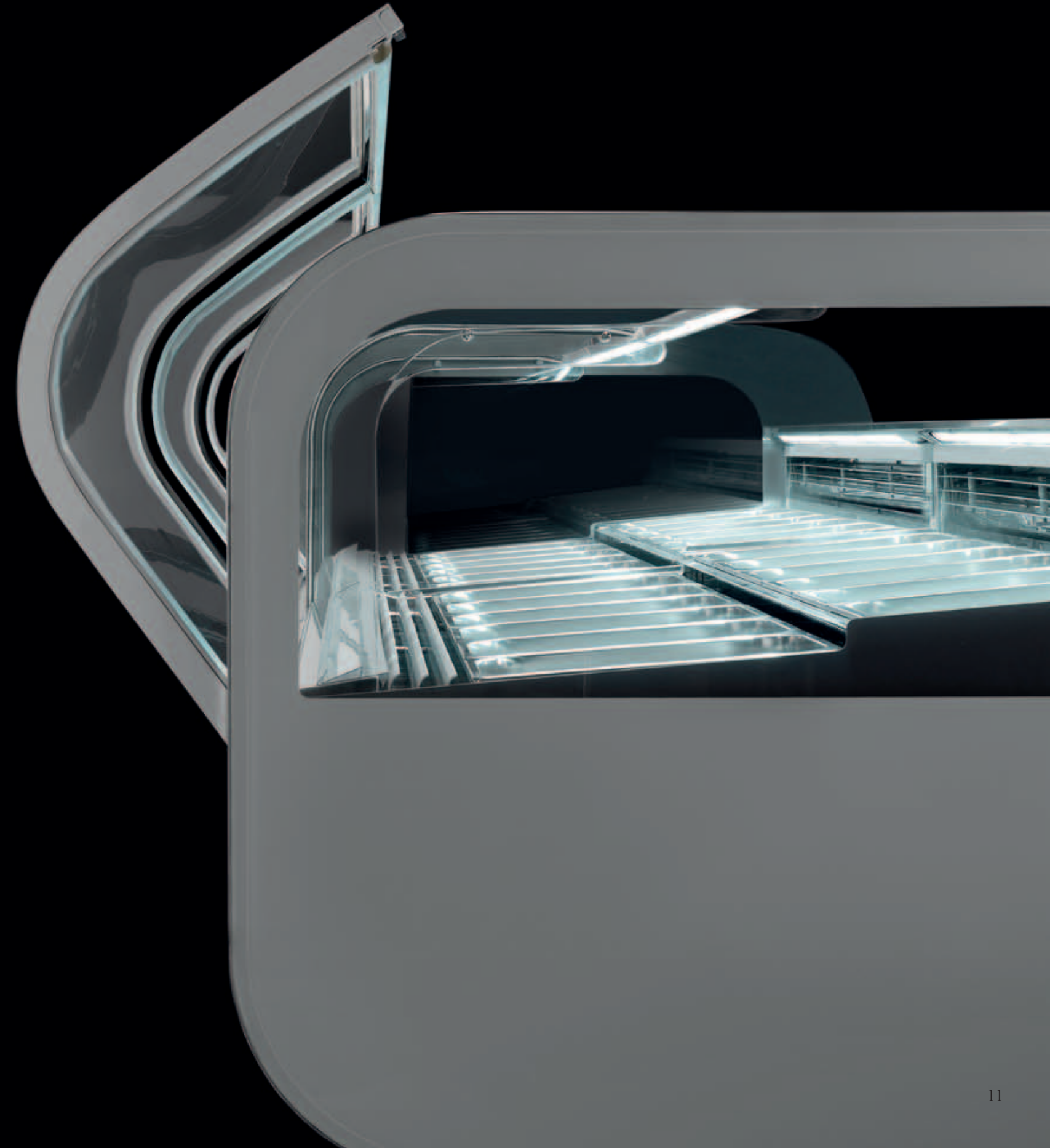
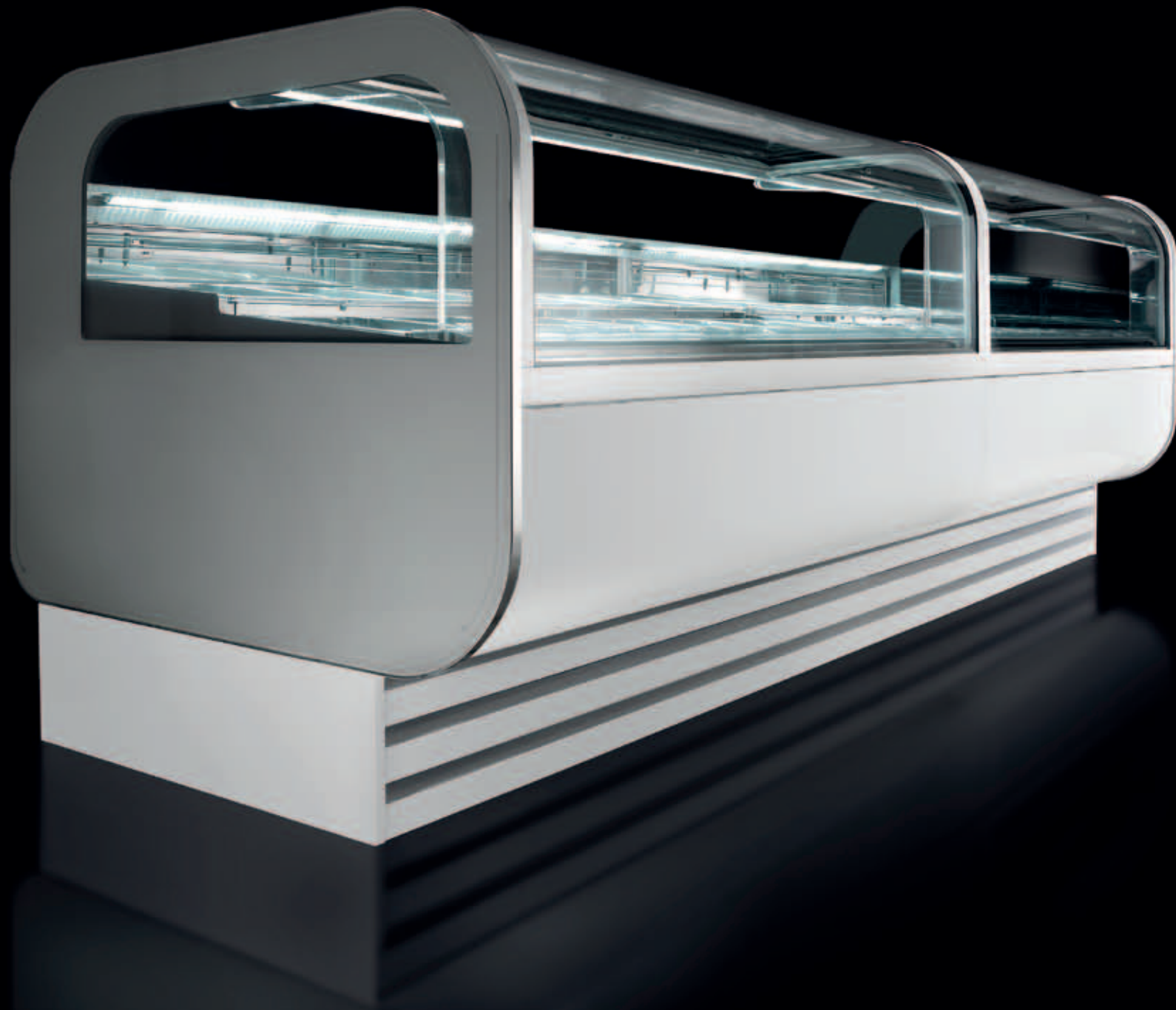



CARATTERISTICHE TECNICHE E GAMMA PRODOTTI

TECHNICAL SPECIFICATIONS AND PRODUCT RANGE

PASTICCERIA FREDDO VENTILATO PASTRY VENTILATED REFRIGERATION

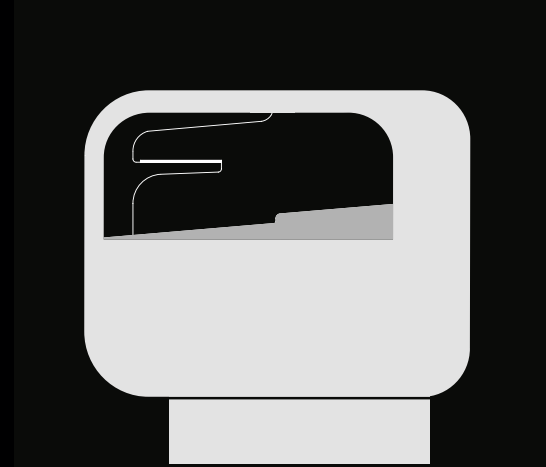
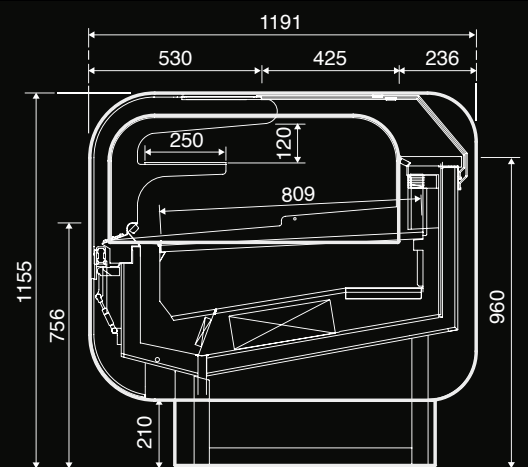

ESTETICA E STRUTTURA

- Vetro frontale stratificato riscaldato
- Apertura vetro frontale verso il basso
- Chiusura lato operatore con scorrevoli in plexiglass
- Plafoniera di illuminazione a led sul tettino e sotto il pianetto di servizio
- Spalle in vetro camera serigrafato (RAL 9003)

TECNOLOGIA

- Impianto refrigerante standard con compressore semirmeritico 380/3/50 Hz (versione gelato) ed ermetico 230/1/50 Hz (versione pasticceria) su unità condensatrici incorporate ad aria
- Pannello di controllo elettronico con termometro e termostato digitali
- Gas refrigerante R404a

PRALINERIA CHOCOLATE CABINET

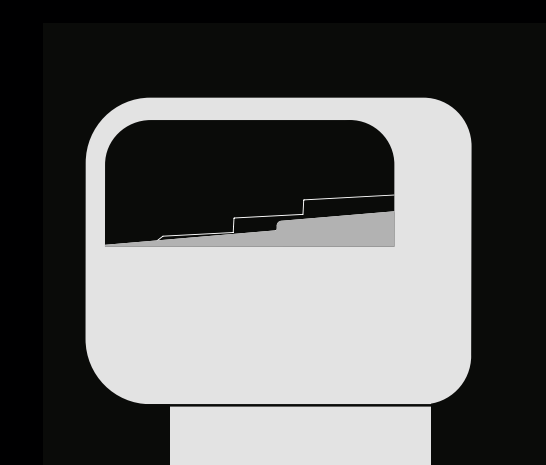
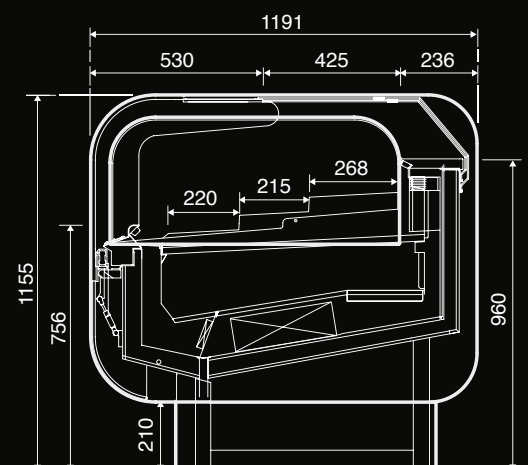

AESTHETIC AND FRAMEWORK

- Double and stratified, heated front glass
- Front glass that can be opened downwards
- Operator's side closing by plexiglass sliding doors
- LED lighting system on the ceiling and under the service top
- End side panels IGU glass with serigraphy (RAL 9003)

TECHNOLOGY

- Standard cooling system with semi-hermetic compressor 380/3/50 Hz on ice cream version and hermetic compressor 230/1/50 Hz on pastry version for incorporated air-cooling condensing units
- Electronic check panel with digital thermometer and thermostat
- Refrigerating gas R404a

GELATERIA ICE-CREAM CABINET

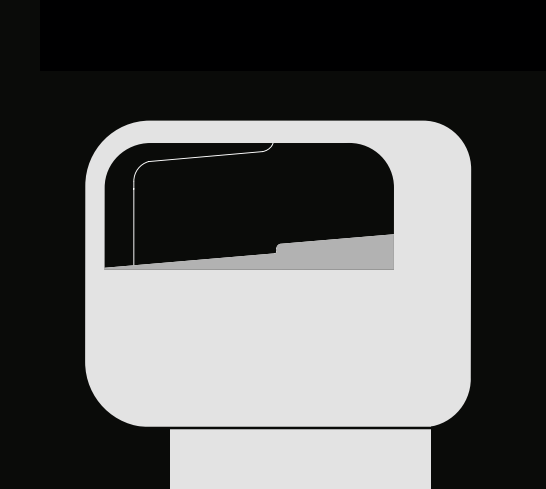
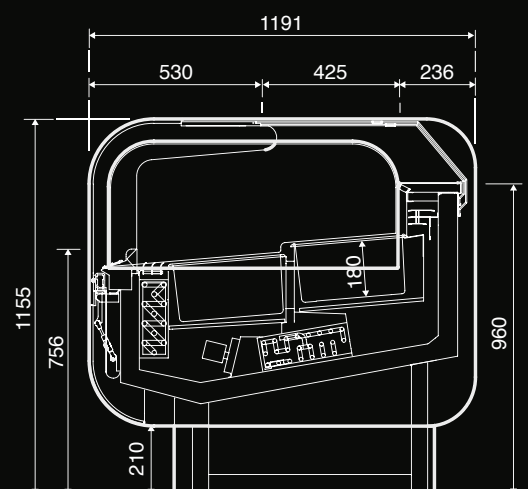

ALLESTIMENTO VASCHE GELATO DISPONIBILI ICE CREAM TUBS

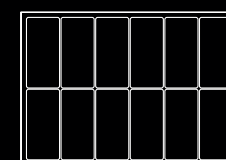

G6

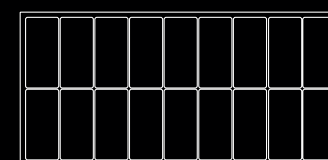

G9

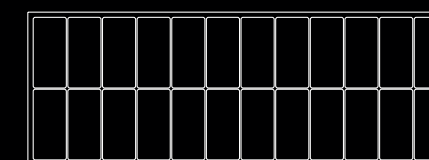

G12

VASCETTA STANDARD
STANDARD ICE-CREAM TUBS
360 x 165 mm

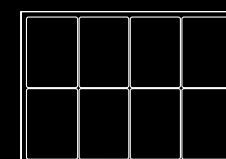

G6

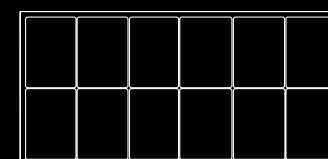

G9

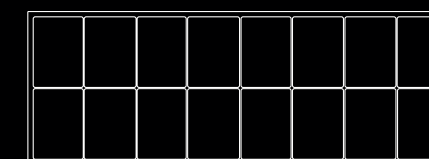

G12

VASCETTA GRANDE
BIG ICE-CREAM TUBS
360 X 250 MM

TABELLA DI RIEPILOGO TECNOLOGIE E DIMENSIONI DISPONIBILI (mm)

FUNCTIONAL AND DIMENSIONAL COMPARATIVE CHART (MM)

GAMMA PRODUCT RANGE	GELATO ICE-CREAM	PASTICCERIA VENTILATA VENTILATED PASTRY	PRALINERIA CHOCOLAT	NEUTRA AMBIENT
1090 mm	•	•	•	•
1615 mm	•	•	•	•
2140 mm	•	•	•	•

TABELLA DI RIEPILOGO TECNOLOGIE E DIMENSIONI DISPONIBILI (mm)

FUNCTIONAL AND DIMENSIONAL COMPARATIVE CHART (MM)

MODULO MODULE	TEMPERATURA DI ESERCIZIO (°C) WORKING TEMP.	RESA (W) COOLING CAP.	ALIMENTAZIONE ELETTRICA ELECTRIC SUPPLY	POTENZA ASSORBITA (W) MAX POWER INPUT	PESO NETTO (KG) NET WEIGHT
RVS 1.1	+4°/+6°	1020	230/1/50hz	830	250
RVS 1.6	+4°/+6°	1200	230/1/50hz	1100	320
RVS 2.1	+4°/+6°	1420	230/1/50hz	1300	400
RP 1.1	+14°/+16°	1020	230/1/50hz	1200	250
RP 1.6	+14°/+16°	1200	230/1/50hz	1760	320
RP 2.1	+14°/+16°	1420	230/1/50hz	2150	400
G 6	-18°/+20°	1530	400/3/50hz	1610	280
G 9	-18°/+20°	2300	400/3/50hz	2290	340
G 12	-18°/+20°	2900	400/3/50hz	2890	420

N.B.: La temperatura di esercizio è riferita a condizioni ambientali di: +30°C/55% UR (classe 4)
N.B.: The working temperature refers to the following environmental conditions: +30°C/55% Relative Humidity (class 4)



FB è un marchio CLABO GROUP s.r.l.
Viale dell'Industria, 15 | Zona ZIPA
60035 Jesi (AN) | Italy
Tel. +39 0731 61531
Fax +39 0731 6153211
www.fbstyle.it | info@fbstyle.it